

CARSON

Carson Manufacturing Co., Inc.
5451 North Rural Street
Indianapolis, IN 46220
Phone: (888) 577-6877 Fax: (317) 254-2667
www.carsonsirens.com

TECHNICAL BULLETIN

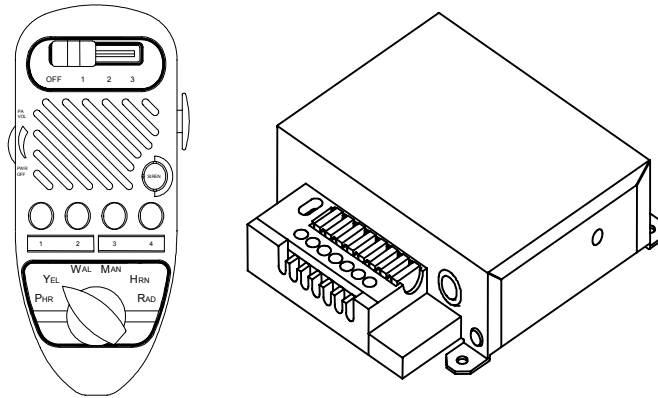

INSTALLATION AND OPERATING MANUAL

SC-550-8X with Circular DIN Hand Control Connector (OLD VERSION)

SC-550-83 14V (Phaser)
SC-550-84 14V (California)
SC-550-85 14V (Two-Tone)

Carson is a trademark of Carson Manufacturing Company, Inc.

WARNING



Sound Hazard - Sound level from siren speaker (>120dBA @ 10 feet) may cause hearing damage. Do not operate siren without adequate hearing protection for you and anyone in immediate vicinity. (Ref. OSHA 1910.95 for occupational noise exposure guidelines)

SC-550-83/84/85 SPECIFICATIONS

AMPLIFIER INPUT POWER:	11-16 Volts DC, 8 Amps DC per 100W Speaker Power off current to amplifier is 20mA Max.
SIREN MODE	
OUTPUT POWER:	15 VDC input, 100W speaker(s) One speaker – 105 Watts RMS Two speakers - 180 Watts RMS
AUDIO MODE	
OUTPUT POWER:	14 VDC input, 100W speaker(s) One speaker – 40 Watts RMS Two speakers - 80 Watts RMS
SIREN	
FREQUENCY:	750Hz - 1650Hz Nominal
CYCLE RATES:	WAIL - 13 cycles/min YELP - 200 cycles/min PHASER - 11 cycle/sec (SC-550-83 only) TWO-TONE – 1 cycle/min (SC-550-85 only)
AUDIO	
RESPONSE:	200Hz - 10KHz +/-3db Harmonic Distortion Less than 3% @ 1KHz
RADIO INPUT	
SENSITIVITY:	0.75VAC Input Min. for 40 Watts RMS Output (1 spkr)
OPERATING	
TEMPERATURE:	-15° F to +140° F
SIZE:	Amplifier 7-1/2" Wide X 2-1/8" High X 6-3/4" Deep Control Head 2-3/4" Wide X 6-3/4" High X 1-3/8" Deep
WEIGHT:	Amplifier 3.5 pounds Hand Control 1 pound
NIGHT VISIBILITY:	Hand Control panel is backlit when turned on.
AMPLIFIER PROTECTION:	High Voltage – Siren output stops with input voltage above highest rating Stops high output power from blowing speaker Reverse Polarity – Fuse(s) blows when power is wired backwards Shorted Output – Fuse(s) blows if speaker shorts (a common problem)
LIGHT CONTROL INPUT POWER:	11-16 Volts DC, 140 Amps Max. not including siren input current.
SLIDE SWITCH OUTPUTS:	20 Amps Max. per terminal.
FOUR AUXILIARY OUTPUTS:	20 Amps Max. per terminal.
LIGHT CONTROL PROTECTION:	Each output terminal fused.

NOTICE

Due to continuous product improvements, we must reserve the right to change any specifications and information, contained in this manual at any time without notice.

Carson Manufacturing Co., Inc. makes no warranty of any kind with regard to this manual, including, but not limited to, the implied warranties of merchantability and fitness for a particular purpose.

Carson Manufacturing Co., Inc. shall not be liable for errors contained herein or for incidental or consequential damages in connection with the furnishing, performance, or use of this manual.

INSTALLATION

Proper installation of the unit is essential for years of safe, reliable operation. Please read all instruction **before** installing the unit. Failure to follow these instructions can cause serious damage to the unit or vehicle and may void warranties.

SAFETY PRECAUTIONS

For the safety of the installer, vehicle operator, passengers and the community please observe the following safety precautions. **Failure to follow all safety precautions and instructions may result in property damage, injury or death.**

Qualifications - The installer must have a firm knowledge of basic electricity, vehicle electrical systems and emergency equipment.

WARNING



Sound Hazard - Sound level from siren speaker (>120dBA @ 10 feet) may cause hearing damage. Do not operate siren without adequate hearing protection for you and anyone in immediate vicinity. (Ref. OSHA 1910.95 for occupational noise exposure guidelines)

Hand Control Location – Locate the hand control for easy access by the vehicle operator. DO NOT locate in air bag deployment area. When using optional holster, assure clearances before drilling in vehicle.

Wiring - Use wiring capable of handling the current required. Make sure all connections are tight. Route wiring to prevent wear, overheating and interference with air bag deployment. Install and check all wiring before connection to vehicle battery.

Testing - Test all siren functions after installation to assure proper operation. Test vehicle operation to assure no damage to vehicle.

Keep These Instructions - Keep these instructions in the vehicle or other safe place for future reference. Advise the vehicle operator of the location.

AUTOMATIC SIREN OPTION

The automatic siren option is normally on (see slide switch operation). To disable automatic siren, remove the amplifier cover (four black screws at corners) and set switch as shown to the right. Once switch is set replace the cover.

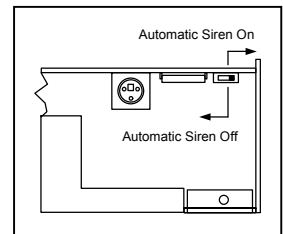

RADIO VOLUME ADJUST

If the Radio repeat mode of the siren is going to be used then the RADIO VOLUME control may need to be adjusted. This is a one time setting which depends on the radio connected and its normal volume. On the hand control, set the slide switch to OFF, set the rotary switch to RADio, and power switch to ON. With the volume on the radio itself set to normal level, set the RADIO VOLUME control to the desired output level. (see electrical connections for control location)

HAND CONTROL MOUNTING

Choose a mounting location convenient to the operator and away from any air bag deployment areas. Consider cable routing to amplifier as well as PA use. Mount the hand control with supplied Hook and Loop tape or Holster. If these methods are not preferred, the hand control may be mounted several ways including a cell phone holder.

Hand Control Plug - Plug cable into amplifier, no other electrical connections are necessary. If it is necessary to disconnect from the amplifier, perform the following sequence to release the locking mechanism on plug:

1. Grip the cable at the end of the connector and apply a slight forward force towards amplifier.
2. Grip the sleeve of the connector (major diameter with the flat side on bottom) and pull away from amplifier until it slides about 1/4" over plug.
3. Pull plug away from the amplifier.

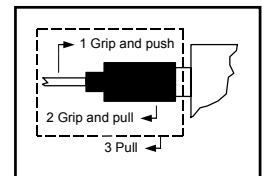

AMPLIFIER MOUNTING

Choose a mounting location in an area such as the driver compartment firewall, under a seat, etc. Mounting the amplifier in the engine compartment or in an area directly exposed to weather is not recommended. Assure adequate ventilation to prevent overheating. Consider wire routing and access to connector. Install amplifier to vehicle using 1/4" hardware (not supplied).

ELECTRICAL CONNECTIONS

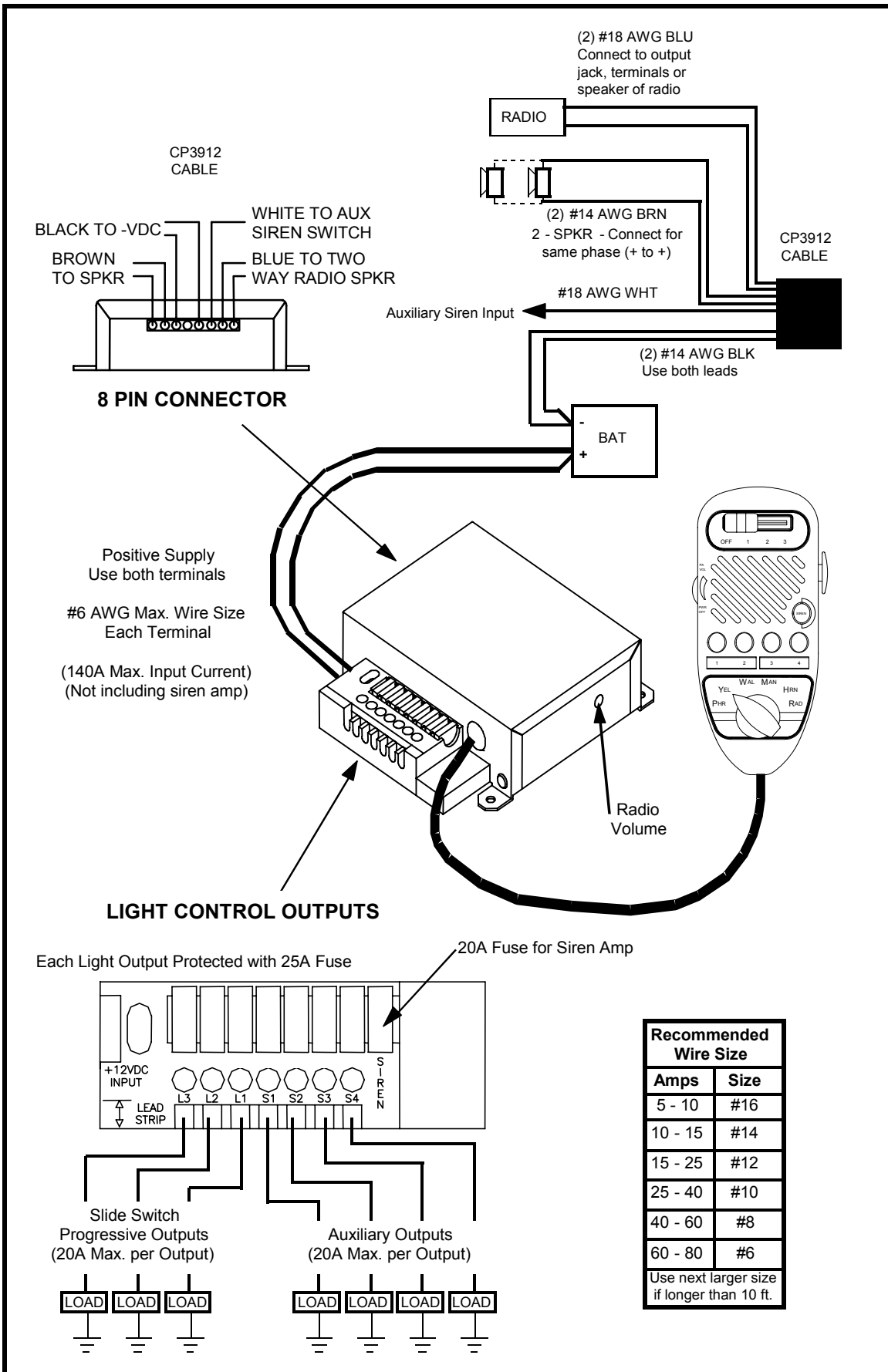

ELECTRICAL CONNECTIONS

Disconnect vehicle battery before making any electrical connections.

Make electrical connections with supplied wiring harness for siren functions and pressure terminals for light control outputs. Wiring for the pressure terminals is not supplied. Follow the diagram recommended wire size for pressure terminals. If necessary, extend wiring harness leads using adequately sized wiring and terminals or splices. If wiring harness leads are extended longer than 10 ft or the pressure terminal leads are longer than 10 ft, use the next larger wire size.

Attach leads to pressure terminals by stripping 3/8", inserting into connector and clamp by tightening screw. Make sure the screw is tight and the wire can't be pulled out.

Failure to adequately tighten the screw can result in improper operation or burning the connector and wire.

Positive Supply: Due to the high current nature of this unit, an appropriate supply line is required. In addition to the high current delivered to devices on the outputs, the siren amplifier will require peak currents up to 50 amps for adequate short circuit protection and reliable operation. The preferred source is directly at the vehicle battery.

Negative Supply: The negative supply line is for the siren amplifier. The siren amplifier will require peak currents up to 50 amps for adequate short circuit protection and reliable operation. The preferred source is directly at the vehicle battery.

Speaker: Both connections must be used. Two speakers may be connected in parallel. Observe polarity (phasing) for maximum sound output.

Radio (Optional): Both connections must be used. The input is isolated and polarity is not important. May need to adjust RADIO VOLUME on side of amplifier.

Auxiliary Siren (Optional):

The auxiliary siren input allows activation of the Siren button with an external source. Connect to a normally open switch or to horn ring circuit. Circuit may connect to either positive or negative for activation. When connected to horn ring circuit, use a SPDT switch to connect horn ring to either vehicle horn or auxiliary input.

Permanent disconnection of the vehicle horn is NOT recommended.

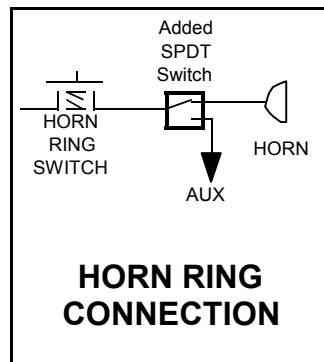

OPERATION

WARNING



Sound Hazard - Sound level from siren speaker (>120dBA @ 10 feet) may cause hearing damage. Do not operate siren without adequate hearing protection for you and anyone in immediate vicinity. (Ref. OSHA 1910.95 for occupational noise exposure guidelines)

SIREN CONTROLS

The combined power switch and volume control give power to the hand control and adjust the PA volume. Power is turned **OFF** by rotating the control counterclockwise until it “clicks”. Power is turned **ON** and increased PA volume by rotating clockwise. The power switch should be turned off when vehicle is not being used to conserve battery power.

The Rotary Function Switch selects various siren operating modes. These modes are as follows:

Phaser: The siren produces a very fast warble tone. This mode may be used at intersections or in highly congested areas. Horn and PA override available in this mode.
Note that Phaser is replaced with Horn on SC-550-84 model or Two Tone on SC-550-85 model.

Yelp: The siren produces a moderate warble tone. This mode may be used in lightly congested areas. Horn and PA override available in this mode.

Wail: The siren produces a normal rise-fall tone pattern. This mode may be used on highways or areas with constant traffic flow. Yelp and PA override available in this mode.

Manual: The siren rise-fall tone is controlled manually with the Siren button. PA override available in this mode.

Horn: Also considered a standby mode. Horn and PA override available in this mode.

Radio: This mode reproduces, or repeats, the output of a radio. The radio must be connected and the RADIO VOLUME adjusted. PA override available in this mode.

The following **VERRIDE FUNCTIONS** are available for certain modes.

PA: By pressing the microphone PTT (Push to Talk) switch on the side of the hand control, the siren will change to a PA (Public Address) amplifier. The siren mode resumes when the PTT is released. Adjust the PA Volume and hold the MIC close to your lips for proper operation. PA override is available in all modes.

Horn: By momentarily pressing the Siren button or activating the auxiliary siren input, the HORN tone is produced. The siren mode resumes when released. Horn override is available in all modes except Radio and Wail.

Yelp: Only available in Wail mode. By momentarily pressing the Siren button or activating the auxiliary siren input, the siren output is toggled between Wail and Yelp tone.

Power Switch/PA Volume



Function Switch

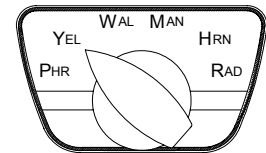

PA and Siren Button

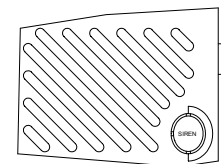

LIGHT CONTROLS

A 4-position slide switch provides control of primary lighting functions. It also provides automatic activation of the siren. Four pushbuttons for additional lighting or controlling other devices. The power switch on the hand control must be **ON** for light controls to function.

Slide Switch: The slide switch provides progressive (additive) control of lighting functions. Position 1 turns on L1 output. Position 2 turns on L1 and L2 outputs. Position 3 turns on L1, L2, and L3 outputs. Position 3 also turns on the siren (Automatic Siren).

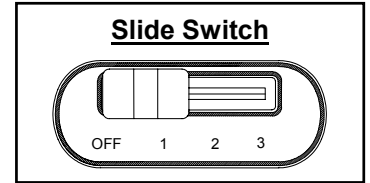

Automatic Siren:

Position 3 of the slide switch provides Automatic Siren. Moving the slide switch to position 3 or powering up the hand control while in position 3 will automatically turn on Yelp regardless of the rotary switch position. Airhorn override is available while in automatic siren. Changing the function switch, pressing the PTT switch, or moving the slide switch off of position 3 will deactivate the automatic siren. Automatic Siren may be completely disabled with the Option Switch.

Auxiliary Output Switches:

Four pushbutton switches are provided for various other lighting functions or device control. Legends above the switch light up when the switch is on.

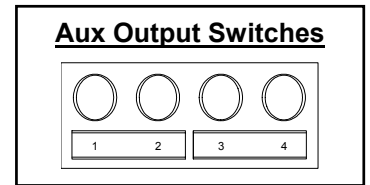

Legend Label Insertion:

Select the desired label insert (provided) and cleanly separate it. Insert the label under the center retainer and tuck each end into the corner pockets.

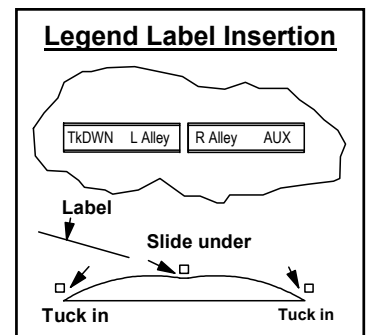

SERVICE

This unit is designed to provide years of reliable service under even the worst conditions. Many times there may appear to be a problem with the unit when the true problem is in the speaker(s), controlled devices, or improper installation. The following chart shows typical symptoms and possible causes.

A blown **siren** fuse doesn't necessarily mean that the unit is bad. If a speaker or speaker lead is shorted this fuse will blow before the unit is damaged. Disconnect the SPKR leads and replace the fuse. If the unit itself emits a low level sound when in the Yelp position it is OK. Check the speaker(s) or leads for possible shorting.

Note: Original shipments of this unit used 20AMP fuses to protect the light control outputs. 25AMP fuses are now recommended to prevent overheating of the output connection block. The outputs should still be limited to 20AMPS.

PROBLEMS

Symptom	Possible Cause	Check
No Power or siren output	Power switch not turned on Bad Speaker Connector or connections loose Siren fuse blown Loose connection at power source	Does backlighting come on? Do you hear a "pop" when turned on? With siren on, yelp selected, listen for tone in amplifier. Is an external fuse or circuit breaker used? Are the power leads connected to a good buss?
No siren tone – PA works	High Voltage Protection PA PTT button stuck	The input voltage must be less than highest rating. Does PTT button release properly?
No PA	PA volume not set properly	Try turning the PA volume control.
Distorted siren sound	Speaker assembly loose Intermittent Aux Input connection Low vehicle voltage	Is the speaker bell or tip loose? Is the Aux Siren Input used and wired properly? The input voltage must be greater than lowest rating.
Intermittent siren tone	High Voltage Protection Connector or connections loose Loose connection at power source PA PTT button activation Circuit breaker in supply connection	Is the vehicle voltage regulator working properly? Is the connector tight on the back of the unit? Check for loose leads back to power source. Is something lying on PTT button? Is a circuit breaker used with at least 50A rating?
Horn or Manual or Two-Tone stuck on	Siren button switch stuck Aux Siren switch stuck Aux Input improperly connected	Does the Siren button switch return fully when released? Does the Aux Siren switch return fully when released? Is the Aux Siren Input used and wired properly?
No Radio	Unit not connected to a radio Radio volume too low	Is the radio connected properly to the unit? Can you hear the radio in the vehicle? Try setting the Radio Volume Adjust.
Wrong siren tone	Automatic Siren Override	Move slide switch off of position 3?
Automatic Siren not working	Automatic Siren disabled	Is the Automatic Siren option off?
Light Output not working	Light Control Output fuse blown Internal relay contacts bad	Is the light or device shorting? Is the output current limited to 20AMPS?
Light Output stays on	Internal relay contacts fused from overheating	Is the output current exceeding 20AMPS?

RETURN

If you have any questions concerning this or any other Carson product, please contact our **Technical Service Department** at (888) 577-6877. Many issues can be handled over the phone. We can also be reached via e-mail at service@carsonsirens.com

If a product must be returned for any reason, please contact our Technical Service Department to obtain a Returned Merchandise Authorization number (RMA#) before you ship the product to Carson. Please write the RMA# clearly on the package near the mailing label. Be sure to provide a return address, contact and phone number, along with a brief description of the problem.

PARTS

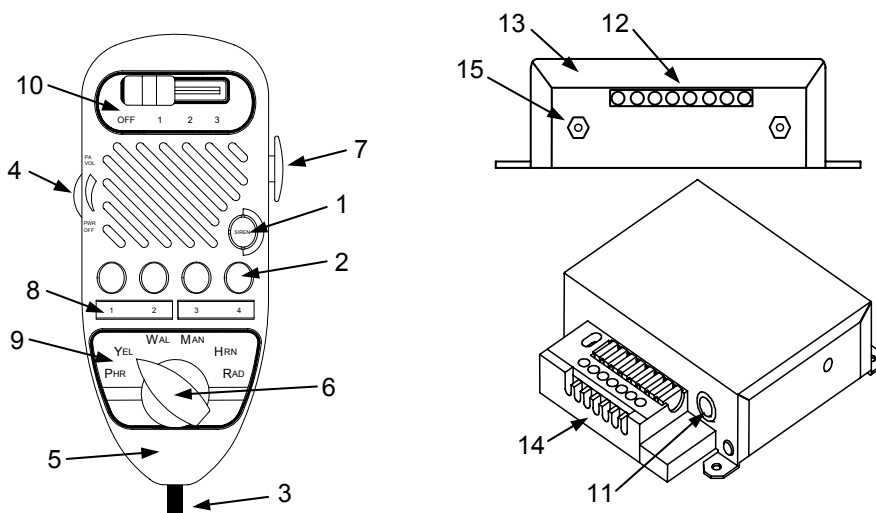

Hand Control

Item	Part #	Description
	CP3941	Bracket, plastic holster mounting
1	CP3918	Button, plastic siren
2	CP3907	Button, plastic aux output (array of 4)
3	CP3905	Cable, coil cord with mini DIN
4	F-16SP/12276	Control, PA volume/power (1K ohm) (SHOKAI #F-16SP/12276)
5	CP3910	Cover, plastic (does not include CP3909 plastic chassis)
6	1555 KNOB	Knob, rotary function switch
7	CP3923	Knob, plastic PA PTT
8	CP3916	Label, replaceable aux output switch indicator
9	CP3903	Label, rotary function switch indicator
10	CP3926	Label, slide switch indicator
	7382 BL	Lamp, right angle T-1-3/4 14V Bi-pin (JKL #7382BL)
	GF0401M	Microphone, speaker transducer (600 ohm) (SHOGYO INTERNATIONAL #GF0401M)
	CP3902	Switch, rotary function

Amplifier

Item	Part #	Description
	CP3912	Cable, amplifier power 8-position
11	70380-A03	Connector, mini DIN 3-pin (PAN INT. #70380-A03 or DIGIKEY #275-1046-ND or SINGATRON #2MJ0101A120)
12	640584-1	Connector, power 8-pin (AMP #640584-1)
13	CP3901	Cover, amplifier (does not include CP3900 chassis)
14	CP3930	Cover, plastic fuse guard
	CP4701	Relay, 40A SPST (AMERICAN ZETTLER #AZ970-1A-12D AgSn)
15	CP4119	Transistor, output (pairs required) (Industry standard TIP36C)