

CARSON

Carson Manufacturing Co., Inc.
5451 North Rural Street
Indianapolis, IN 46220
Phone: (888) 577-6877 Fax: (317) 254-2667
www.carsonsirens.com

TECHNICAL BULLETIN

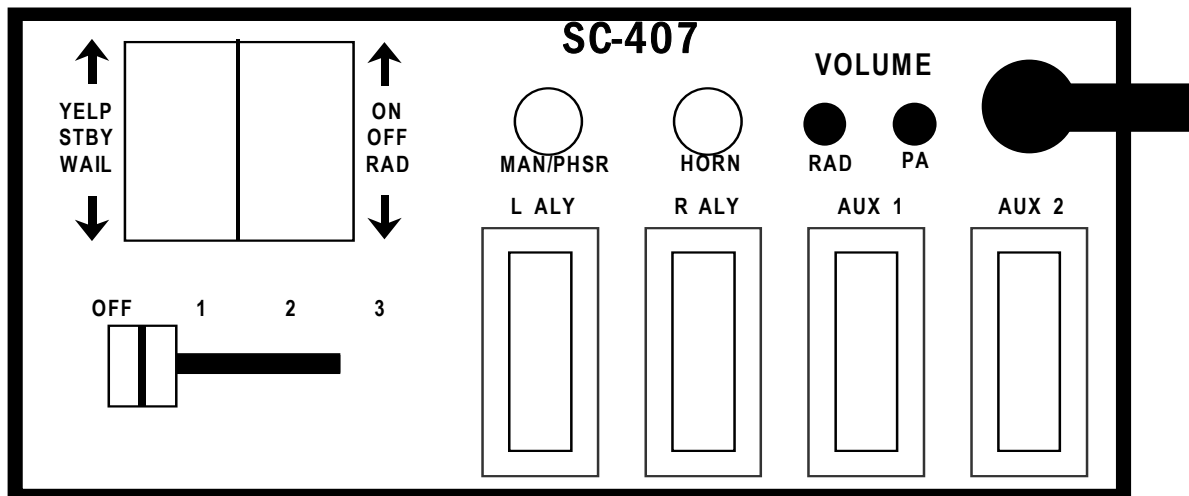

INSTALLATION AND OPERATING MANUAL

SC-407-10 14V (OLD VERSION)

Different Auxiliary and Cutout Input Polarity Options

Carson is a trademark of Carson Manufacturing Company, Inc.

WARNING



Sound Hazard - Sound level from siren speaker (>120dBA @ 10 feet) may cause hearing damage. Do not operate siren without adequate hearing protection for you and anyone in immediate vicinity. (Ref. OSHA 1910.95 for occupational noise exposure guidelines)

SC-407-10 SPECIFICATIONS

AMPLIFIER INPUT POWER:	9-16 Volts DC, 8 Amps DC per 100W Speaker
SIREN MODE	
OUTPUT POWER:	15 VDC input, 100W speaker(s) One speaker – 105 Watts RMS Two speakers - 180 Watts RMS
AUDIO MODE	
OUTPUT POWER:	14 VDC input, 100W speaker(s) One speaker – 40 Watts RMS Two speakers - 80 Watts RMS
SIREN	
FREQUENCY:	700Hz - 1450Hz Nominal
CYCLE RATES:	WAIL - 15 cycles/min YELP - 210 cycles/min PHASER - 15 cycle/sec TWO-TONE – 1 cycle/min
AUDIO	
RESPONSE:	200Hz - 10KHz +/-3db Harmonic Distortion Less than 3% @ 1KHz
RADIO INPUT	
SENSITIVITY:	0.75VAC Input Min. for 40 Watts RMS Output (1 spkr)
OPERATING	
TEMPERATURE:	-15° F to +140° F
SIZE:	6-1/8" Wide X 2-7/8" High X 5-7/8" Deep
WEIGHT:	5 pounds
NIGHT VISIBILITY:	Backlit front control panel when power is on
AMPLIFIER PROTECTION:	High Voltage – Siren output stops with input voltage above highest rating Stops high output power from blowing speaker Reverse Polarity – Fuse(s) blows when power is wired backwards Shorted Output – Fuse(s) blows if speaker shorts (a common problem)
LIGHT CONTROL INPUT POWER:	9-16 Volts DC, 140 Amps Max. not including siren input current.
LEVER SWITCH OUTPUTS:	30 Amps Max. per circuit, 60Amps Max. Total.
FOUR AUXILIARY OUTPUTS:	20 Amps Max. per circuit.
LIGHT CONTROL PROTECTION:	None.

NOTICE

Due to continuous product improvements, we must reserve the right to change any specifications and information, contained in this manual at any time without notice.

Carson Manufacturing Co., Inc. makes no warranty of any kind with regard to this manual, including, but not limited to, the implied warranties of merchantability and fitness for a particular purpose.

Carson Manufacturing Co., Inc. shall not be liable for errors contained herein or for incidental or consequential damages in connection with the furnishing, performance, or use of this manual.

See www.carsonsirens.com for latest information.

INSTALLATION

Proper installation of the unit is essential for years of safe, reliable operation. Please read all instruction **before** installing the unit. Failure to follow these instructions can cause serious damage to the unit or vehicle and may void warranties.

SAFETY PRECAUTIONS

For the safety of the installer, vehicle operator, passengers and the community please observe the following safety precautions. **Failure to follow all safety precautions and instructions may result in property damage, injury or death.**

Qualifications - The installer must have a firm knowledge of basic electricity, vehicle electrical systems and emergency equipment.

WARNING



Sound Hazard - Sound level from siren speaker (>120dBA @ 10 feet) may cause hearing damage. Do not operate siren without adequate hearing protection for you and anyone in immediate vicinity. (Ref. OSHA 1910.95 for occupational noise exposure guidelines)

Mounting - Mount the unit for easy access by the vehicle operator. DO NOT mount in air bag deployment area. Assure clearances before drilling in vehicle. To prevent internal damage mounting bolts must not enter case more than 1/4".

Wiring - Use wiring capable of handling the current required. Make sure all connections are tight. Route wiring to prevent wear, overheating and interference with air bag deployment. Install and check all wiring before connection to vehicle battery.

Testing - Test all siren functions after installation to assure proper operation. Test vehicle operation to assure no damage to vehicle.

Keep These Instructions - Keep these instructions in the vehicle or other safe place for future reference. Advise the vehicle operator of the location.

MOUNTING

The mounting bracket supplied can be installed above or below the unit. Choose a mounting location convenient to the operator and away from any air bag deployment areas. Inspect behind mounting area for clearance. Assure adequate ventilation to prevent overheating. Consider wire routing and access to connections, as well as microphone bracket placement. Install mounting bracket to vehicle using 1/4" hardware (not supplied).

If mounting in a rack or console, make sure that mounting bolts do not enter case more than 1/4".

A microphone clip along with mounting screws (CP3633) holds the microphone in place.

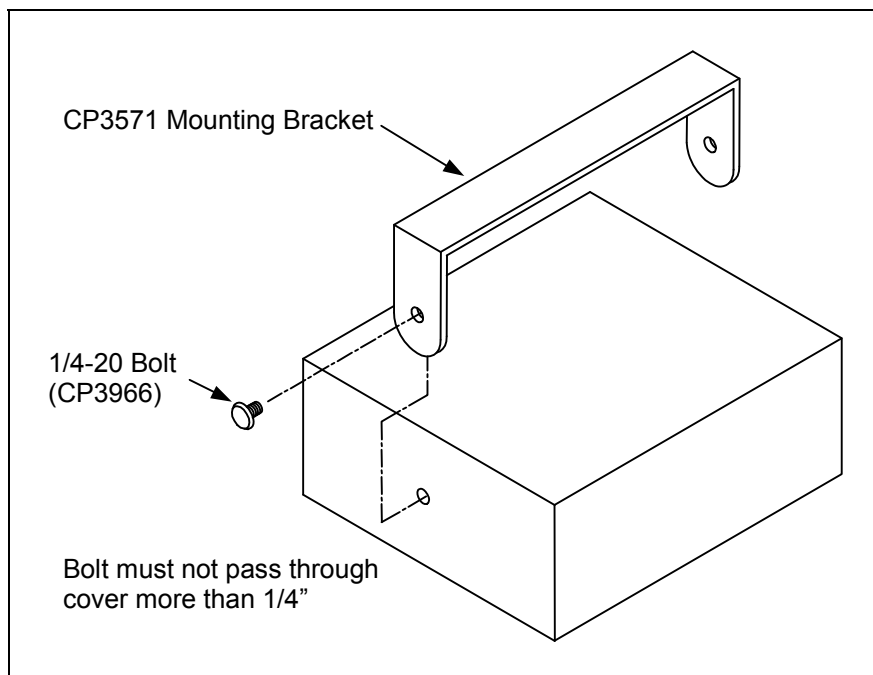

INSTALLER-SELECTABLE OPTIONS

Carefully cutting programming resistor jumpers or traces on the printed circuit board inside the case can select various options. The cover must be removed to access the jumpers. The cover is held in place by a snap-fastener on the back of the unit. Hold the unit with the front case flange on the edge of a hard surface and press hard on the back of the unit. The chassis will slide out the front of the cover.

Auxiliary Input Function - The auxiliary input normally activates the Horn function. To activate the Man/Phsr function with the auxiliary input cut the jumper resistor labeled "AUX I".

Auxiliary Input Polarity - The auxiliary input is normally activated by connecting to ground. To activate by connecting to positive cut the jumper resistor labeled "AUX P".

Cutout Input Polarity - The cutout input is normally activated by connecting to ground. To activate by connecting to positive cut the jumper resistor labeled "CUT P".

Two-Tone - Two-Tone can replace Phaser by cutting the jumper resistor labeled "T-T".

Phaser Disable - The Phaser function can be completely disabled by cutting the jumper resistor labeled "PHSR".

Horn Ring Cyclor option (HRC) - This option allows selection of Wail, Yelp, Phaser and Standby by repeatedly pressing horn ring or other switch connected to the auxiliary input. It is selected by cutting both the "AUX I" and "PHSR" jumper resistors. This disables Phaser operation in the Wail or Yelp positions

Horn Disable - The Horn function can be disabled by cutting the trace on the back of the board at the location designated "cut to disable horn".

Automatic Siren Disable - To disable automatic siren operation when the lever switch is in position 3, cut and remove the red wire attached to the lever switch relay board inside the unit.

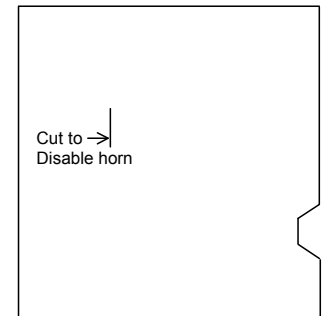
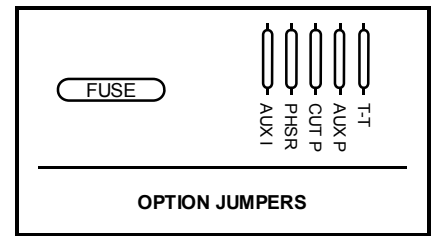

ELECTRICAL CONNECTIONS

Disconnect vehicle battery before making any electrical connections.

Make electrical connections with supplied terminal block plug for siren functions and spliced lead wires for light control outputs. Wiring is not supplied.

Siren Connections

Electrical connections to the siren section are made using a removable terminal block plug located on the back. A label on the unit identifies the terminal function. You should install the connector on the unit before wiring. If the unit needs service the connector can be easily removed without unwiring the connector.

The power supply of the unit must be capable of delivering peak currents up to 50 amps for adequate short circuit protection and reliable operation. The preferred source is directly at the vehicle battery. The unit is internally fused.

Attach leads by stripping 3/8", inserting into connector and clamp by tightening screw. Make sure the screw is tight and the wire can't be pulled out. **Failure to adequately tighten the screw can result in improper operation or burning the connector and wire.**

Wire Size and Termination - The diagram shows the minimum wire size used for each connection, along with recommended lead color. If the wire is longer than 10 ft. use the next larger wire size. Use only high quality crimp connectors for installation on the vehicle.

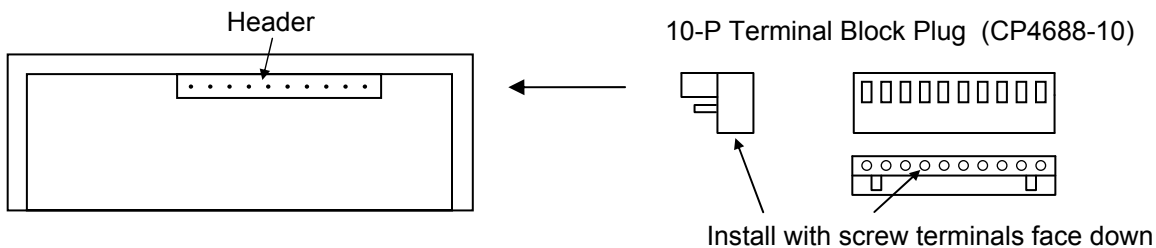
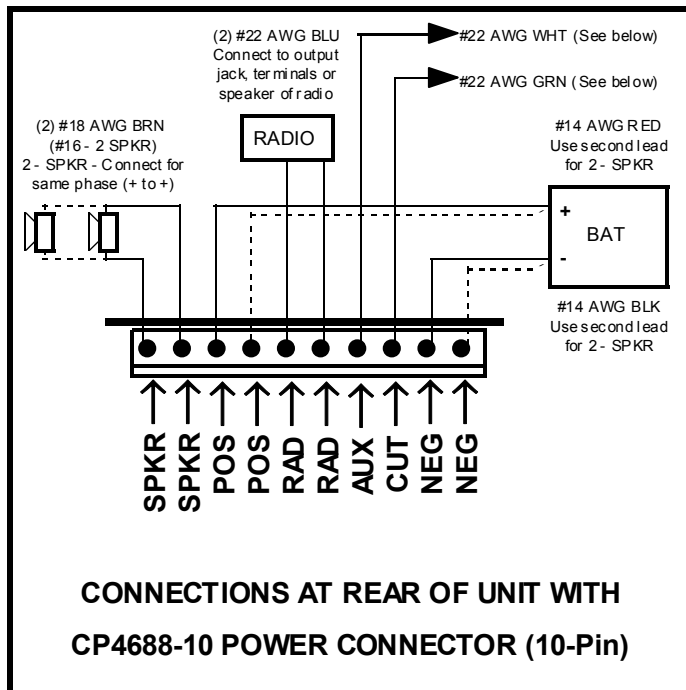

Auxiliary Input Connection - The Auxiliary Input allows activation by an external source of either the Horn or Man/Phsr function. The adjacent diagram shows three connection examples. See the INSTALLER-SELECTABLE OPTIONS section for programming details.

If positive switching is used for the auxiliary (AUX) Input and the connection to the destination device (horn) is removed a resistor (1 supplied) must be added between the AUX input and ground for proper operation. A symptom of this problem is continual activation of the auxiliary function when the horn ring is not pressed.

NOTE: Permanent disconnection of the vehicle horn is NOT recommended.

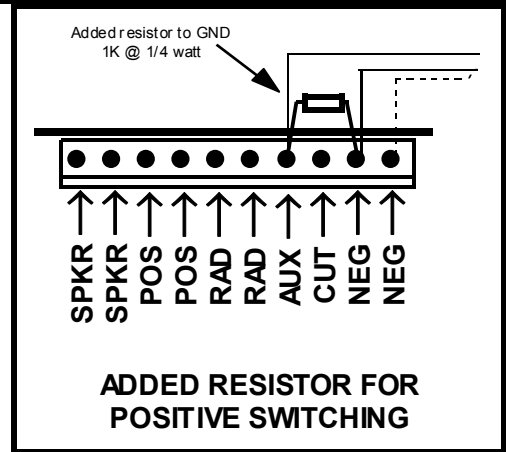
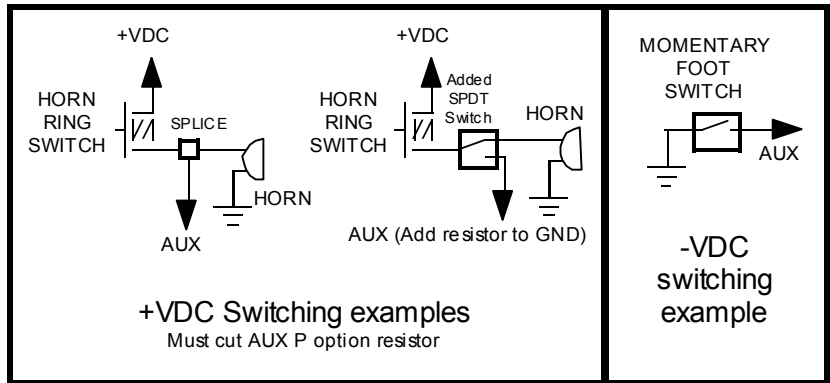

Cutout Input Connection - The Cutout Input turns off any siren tone output when activated, and remains off until a control is activated or changed. The adjacent diagram shows two connection examples. See the INSTALLER-SELECTABLE OPTIONS section for programming details.

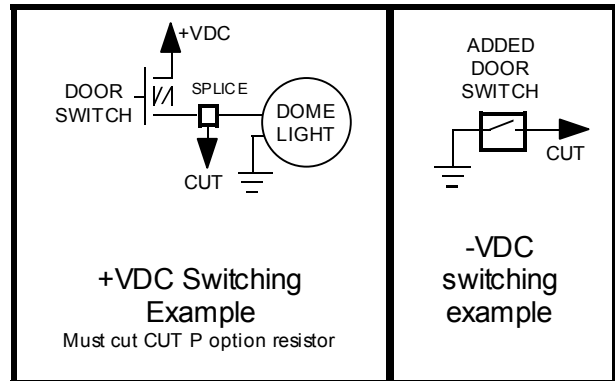

Light Control Connections

In addition to these instructions a label located on the bottom of the unit shows the light control switch connections.

Fuses / Breakers

The lighting control circuits of this unit **are not fused**. Automotive fuses or circuit breakers must be connected between the power source and the unit properly rated for the circuit requirements. **Failure to install proper circuit breakers or fuses can result in damage to the unit and/or vehicle.**

Lever Switch Connections

The following diagram shows proper connection of the lever switch leads located at the rear.

Note: Negative (NEG) connection must also be made on 10-Pin connector for proper operation.

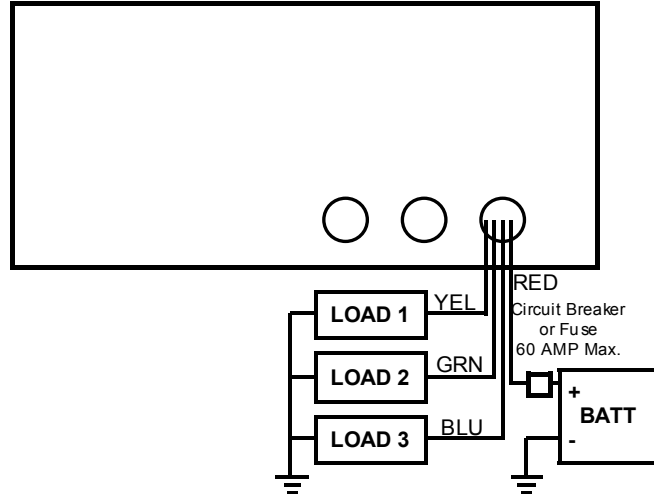

Recommended Wire Size	
Amps	Size
5 - 10	#16
10 - 15	#14
15 - 25	#12
25 - 40	#10
40 - 60	#8
60 - 80	#6
Use next larger size if longer than 10 ft.	

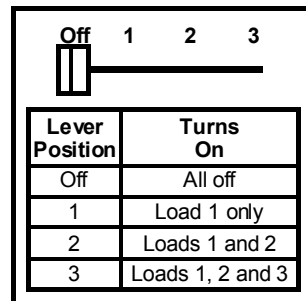

Light Control Rocker Switch Connections

The following diagram shows proper connection of the rocker switch leads located at the rear.

Note: Negative (NEG) connection must also be made on 10-Pin connector for rocker switches to light up.

WARNING: The lighting control circuits of this unit **are not fused**. Automotive fuses or circuit breakers must be connected between the power source and the unit properly rated for the circuit requirements. **Failure to install proper circuit breakers or fuses can result in damage to the unit and/or vehicle.**

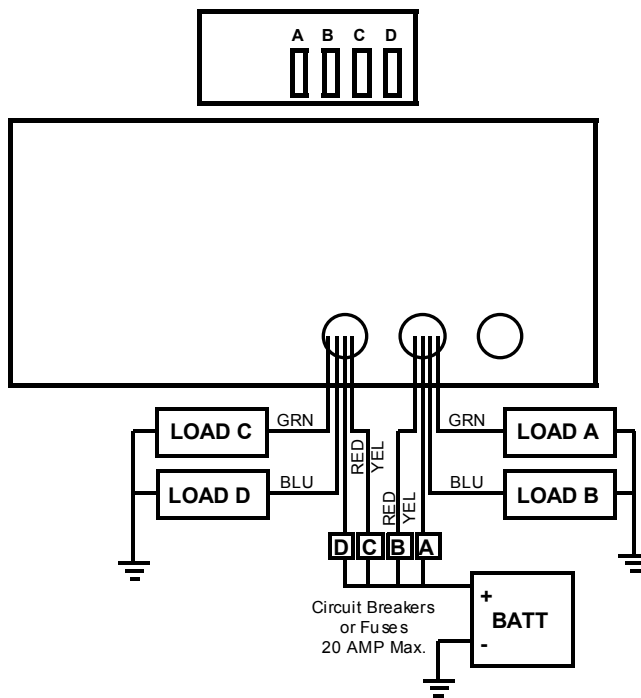

Recommended Wire Size	
Amps	Size
5 - 10	#16
10 - 15	#14
15 - 30	#12
30 - 40	#10
40 - 50	#8
50 - 60	#6
Use next larger size if longer than 10 ft.	

Switch Lead Sets		
Switch	Leads	Hole
A	GRN/YEL	Center
B	BLU/RED	Center
C	GRN/YEL	Left
D	BLU/RED	Left

OPERATION

WARNING



Sound Hazard - Sound level from siren speaker (>120dBA @ 10 feet) may cause hearing damage. Do not operate siren without adequate hearing protection for you and anyone in immediate vicinity. (Ref. OSHA 1910.95 for occupational noise exposure guidelines)

SIREN CONTROLS

Two 3-position rocker switches control the primary operating modes of siren. These modes are as follows:

On: Applies power to the siren system for operation independent of light control system. It also turns on backlighting for night use. The switch should be turned off when vehicle is not being used to conserve battery power.

Off: Turns off power to the siren section.

Radio: This mode reproduces, or repeats, the output of a radio. The radio must be connected and RADIO VOLUME on the face adjusted. No siren tones or PA operation are available in this position.

Wail: The siren produces a normal rise-fall tone pattern. This mode may be used on highways or areas with constant traffic flow.

Yelp: The siren produces a moderate warble tone. This mode may be used in lightly congested areas.

Standby: A silent mode that allows Manual, Horn and Public Address operation.

Manual / Phaser:

With the mode switch in the Standby position this push-button switch provides Manual siren tone control, rising when pressed and falling when released. When the mode switch is in the Yelp or Wail positions, the push-button provides Phaser tone. This tone is a very fast warble tone used at intersections or in highly congested areas. Pressing the button once changes to the Phaser tone and pressing again changes the tone back to Yelp or Wail. Optional operation includes replacement of the Phaser tone with Two-Tone or disabling the Phaser tone entirely



Horn: This push-button switch provides a simulated air-horn tone while pressed. This can be used to supplement the normal vehicle horn and is useful at intersections or in low noise areas. This tone will override all other siren tones.

PA: Pressing the microphone button in any mode except Radio changes the unit to PA (Public Address). The siren mode resumes when the button is released. Adjust the PA Volume and hold the microphone close to your lips for proper operation.

Volume Controls

Volume controls are provided for radio repeat function volume and public address volume. These should be set when the vehicle is parked. Set the RAD volume with the selector switch in the Radio position and the radio volume set to desired level. Set the PA volume to the maximum level with no feedback (squeal).

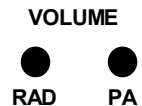

Auxiliary Input

During installation an auxiliary input may be connected to the horn ring or other switching device. It provides the same operation as pressing the Horn button or optionally the Man/Phsr button.

Cutout

During installation a cutout input may be connected to a door switch. It turns off any siren tone when the door is opened. The siren tone will continue to be cut off even when the door is closed. Changing any siren control switch or input will restore normal function.

Horn Ring Cyclor (Optional)

During installation, the auxiliary input may be connected to the horn ring or other switching device, and the HRC option programmed. With the mode switch set to the Standby position, the horn ring can be pressed repeatedly to select the Wail, Yelp, Phaser and Standby tones or modes in succession. Operating any other switch resumes normal operation. Please note that this option disables Phaser selection in the Wail or Yelp selector switch positions.

LIGHT SYSTEM CONTROLS

This unit provides large, durable switches for light control function. A 4-position lever switch provides control of primary lighting functions. It also provides automatic activation of the siren system.

Setting the siren control switch to the On position can turn on backlighting of the light control switches.

Lever Switch

The lever switch provides additive control of lighting functions. Position 1 turns on a single lighting function, such as lights pointing to the rear. Position 2 turns on an additional light function, such as lights pointing to the front. Position 3 turns on an additional 3rd lighting function, such as strobes. Position 3 also turns on a siren function (see below). The installer determines actual function.



Automatic Siren

Position 3 of the lever switch provides automatic siren control. With both siren control rocker switches set at center position (Stby/Off) the unit will activate the Wail siren tone. With the siren control switches set at Yelp/Off position 3 will activate the Yelp siren tone. The Man/Phsr and Horn switches will operate as if the siren control switches were set at the corresponding positions. PA override is also functional. Automatic siren operation will not work if the right siren control switch is set in the Rad position or the installer has disabled the function.

Rocker Switches

Four rocker switches are provided for various other lighting functions, such as alley lights, deck lights, headlight flashers, etc. The switches light when turned on for night use.

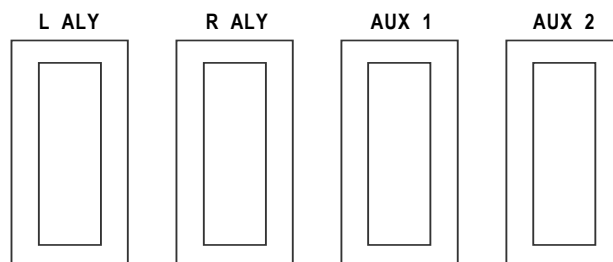

SERVICE

This unit is designed to provide years of reliable service under even the worst conditions. Many times there may appear to be a problem with the unit when the true problem is in the speaker(s), controlled devices, or improper installation. The following chart shows typical symptoms and possible causes.

A blown internal **siren** fuse doesn't necessarily mean that the unit is bad. If a speaker or speaker lead is shorted this fuse will blow before the unit is damaged. Disconnect the SPKR leads and replace the fuse. If the unit itself emits a low level sound when in the Yelp position it is OK. Check the speaker(s) or leads for possible shorting.

PROBLEMS

Symptom	Possible Cause	Check
No Power or siren output	Power switch not turned on Bad Speaker Connector or connections loose Internal siren fuse blown Loose connection at power source	Does backlighting come on? Do you hear a "pop" when turned on? With siren on, yelp selected, listen for tone in amplifier. Is an external fuse or circuit breaker used? Are the power leads connected to a good buss?
No siren tone – PA works	High Voltage Protection Mic button stuck Cutout activated Cutout Polarity Option set wrong	The input voltage must be less than highest rating. Does mic button release properly? Does siren work when Cutout input is disconnected? Is the CUT P option properly configured?
No PA	PA volume not set properly Selector in Radio position	Try turning the PA volume control. PA is not available in the Radio position.
Distorted siren sound	Speaker assembly loose Intermittent Aux Input connection Low vehicle voltage	Is the speaker bell or tip loose? Is the Aux Input used and wired properly? The input voltage must be greater than lowest rating.
Intermittent siren tone	High Voltage Protection Connector or connections loose Loose connection at power source Mic button activation Circuit breaker in supply connection	Is the vehicle voltage regulator working properly? Is the connector tight on the back of the unit? Check for loose leads back to power source. Is something lying on the microphone? Is a circuit breaker used with at least 50A rating?
Horn or Manual or Phaser stuck on	Horn switch stuck Man/Phsr switch stuck Aux Input improperly connected Aux Input Polarity Option set wrong	Does the Horn switch return fully when released? Does the Man/Phsr switch return fully when released? Is the Aux Input used and wired properly? Is the AUX P option properly configured?
No Radio	Unit not connected to a radio Radio volume too low	Is the radio connected properly to the unit? Can you hear the radio in the vehicle? Try turning the RAD volume control.
Wrong siren tone	Two-Tone option installed. Aux Input set to wrong function	Is the T-T option jumper cut? Is the AUX I option jumper configured properly?
Phaser not working	Phaser disabled	Is the PHSR option jumper cut?
Horn not working	Horn disabled	Is the trace cut that disables the Horn switch?
Automatic Siren not working	Selector in Radio position Automatic Siren disabled	Siren tone is not available in Radio position. Is the internal red lead cut from lever switch board?
Automatic Siren in all lever switch positions	No power to red lever switch lead	Do the lever switch relays turn on devices? Check for power at red lever switch lead.
Lever switch not working in all positions	No power to red lever switch lead No ground at siren connector	Do the lever switch indicators light? Check for power at red lever switch lead.
Lever switch not working in some positions	Loose lever switch output connection on lead	Does the lever switch indicator light?
Lever switch not working in some positions	Loose lever switch output connection on lead	Does the lever switch indicator light?
Lever switch output stays on	Internal relay contacts fused from overheating	Is the output current exceeding 20AMPS?
Rocker switch outputs not working	No power to rocker switch Loose rocker switch output connection on lead	Is the corresponding fuse blown? Does the rocker switch indicator light turn on?

RETURN

If you have any questions concerning this or any other Carson product, please contact our **Technical Service Department** at (888) 577-6877. Many issues can be handled over the phone. We can also be reached via e-mail at service@carsonsirens.com

If a product must be returned for any reason, please contact our Technical Service Department to obtain a Returned Merchandise Authorization number (RMA#) before you ship the product to Carson. Please write the RMA# clearly on the package near the mailing label. Be sure to provide a return address, contact and phone number, along with a brief description of the problem.

PARTS

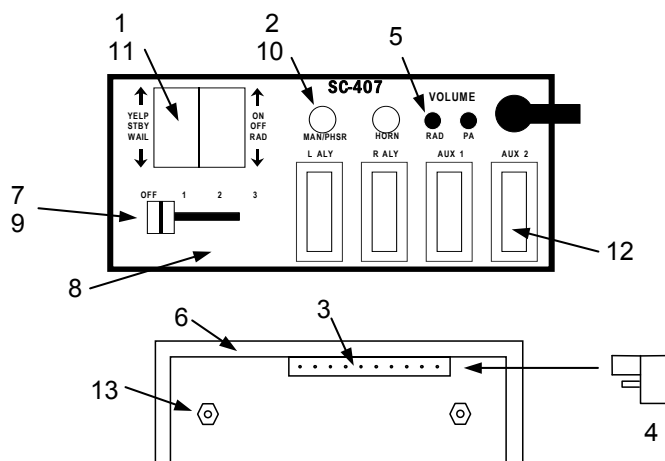

Item	Part #	Description
1		Actuator, White (for rocker selector switch) (substitute CP4968 red actuator)
2	CP4686	Button, Switch Cap White (for pushbutton switch) (substitute CP4837 red button)
3	CP4687-10	Connector, 10-P header
5	CP4684	Control, 1K Vertical w/ Knurled Shaft (PA or Radio Volume)
6	CP4691-1	Cover with stud (does not include CP4690 Chassis)
	ATO/ATC 20A	Fuse, 20 Amp Automotive
7	CP4700	Knob, Lever Switch, red (substitute CP4960 black knob)
8	CP4844	Label, front panel
	CP3570	Microphone, Noise Canceling
	SR-15-1	Microphone Strain Relief
	CP4701	Relay, 40A SPST light control
9	CP4699	Switch, Lever
10	CP4685	Switch, Momentary Push Button, (Horn and Man/Phsr)
11	CP4695	Switch, Rocker Selector, YELP-STBY-WAIL or ON-OFF-RAD (not including actuator)
12	CP4696	Switch, Rocker, Aux light control
13	CP4119	Transistor, output (2 required)
	Accessory	Description
	CP3633	Bracket, Microphone Clip with mounting screws
	CP3571	Bracket, 'U' Dash Mount
	CP3966	Bolts, 'U' Mounting Bracket, 1/4-20 X 3/8 (typically 2 ea required)
	ED1756	Cable, 10-P Lead Assembly 8FT (made w/ CP4688-10 Connector)
4	CP4688-10	Connector, 10-P Terminal Block Plug
	ED1558	Kit, Hardware (includes CP3966 bolts, CP4688-10 connector, CP3633 mic clip)